

# AtriCure®

## AtriCure® Isolator® Synergy™ Surgical Ablation System (EMR2, EML2)

### Instructions for Use

#### DESCRIPTION

The AtriCure ISOLATOR Synergy Surgical Ablation System is comprised of the Ablation and Sensing Unit (ASU), an AtriCure ISOLATOR Synergy device, and a footswitch. The ISOLATOR is a single patient use electrosurgical instrument designed for use only with the ASU. The ISOLATOR is used for cardiac tissue ablation. When activated, the ASU delivers radiofrequency (RF) energy to the linear electrodes on the insulated jaws of the ISOLATOR. The Operator controls the application of this RF energy by pressing the Footswitch.

All ISOLATOR Synergy devices are configured as vascular clamps and feature clamping jaws of various lengths and curvatures.

The AtriCure ISOLATOR Synergy (See Figure 1) Clamps feature an in-line handle with syringe-type actuation and button release mechanisms. The Guide is packaged with ISOLATOR devices that have the Attachment Tip.

The GLIDEPATH™ Tape Instrument Guide is a single patient, surgical device designed to facilitate the guidance of surgical instruments through soft tissue during general surgical procedures.

**NOTE: Please refer to the AtriCure ASU and ASB3 Instructions for Use for information specific to the ASU and ASB3.**

#### ATRICURE ISOLATOR SYNERGY ILLUSTRATION AND NOMENCLATURE

(Figure 1)

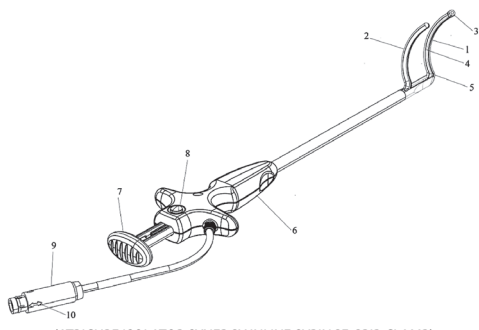

(ATRICURE ISOLATOR SYNERGY INLINE SYRINGE GRIP CLAMP)

- |                   |                               |
|-------------------|-------------------------------|
| 1. Distal Jaw     | 6. Handle                     |
| 2. Proximal Jaw   | 7. Closure Lever              |
| 3. Attachment Tip | 8. Release Mechanism          |
| 4. Electrode      | 9. Connector                  |
| 5. Jaw Heel       | 10. Connector Alignment Arrow |

#### GLIDEPATH TAPE INSTRUMENT GUIDE ILLUSTRATION AND NOMENCLATURE

(Figure 2)

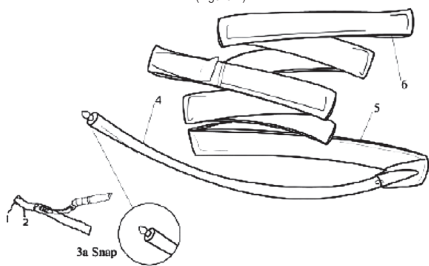

(Guide)

- |                              |                       |
|------------------------------|-----------------------|
| 1. Lateral Tab               | 4. Red Elastic Leader |
| 2. Distal Pocket             | 5. Clear Ribbon       |
| 3. Instrument Attachment Tip | 6. Accessory Ribbon   |

#### INDICATION FOR USE

The AtriCure Bipolar (Transpolar) System is intended to ablate cardiac tissue during surgery.

#### CONTRAINDICATIONS

The Bipolar (Transpolar) System is not indicated for contraceptive coagulation of the fallopian tubes.

#### Potential Complications

##### Device

Possible complications related to the creation of the linear lesions in cardiac tissue using a clamp-type device maybe be included but not limited to:

- Tissue Cutting
- Perioperative heart rhythm disturbance (atrial and/or ventricular)
- Postoperative embolic complications
- Pericardial effusion or tamponade
- Damage to adjacent nerve and/or blood vessels
- Valve leaflet damage
- Conduction disturbances (SA/AV node)
- Acute ischemic myocardial event
- Injury to unintended surrounding tissue structures, including tears and punctures.
- Bleeding requiring intervention to repair.
- Extension of cardiopulmonary bypass

#### Procedure

Serious adverse events that may be associated with surgical ablation procedures on the heart (stand alone or concomitant to other cardiac surgery), include:

- Death
- Excessive bleeding related to the procedure (defined as bleeding which requires >3 units of blood products and/or surgical intervention),
- Cardiac tamponade (if either open or catheter drainage is required),
- Pulmonary vein stenosis,
- Restrictive (constrictive) pericarditis,
- Endocarditis,
- Myocardial infarction (MI) per ACC guidelines,
- Stroke (resulting in permanent neurological deficit),
- Transient Ischemic Attack (TIA),
- Thromboembolism
- Diaphragmatic paralysis,

- Esophageal-LA fistula or esophageal rupture,
- Atrial perforation or rupture,
- Ventricular perforation or rupture,
- Atelectasis,
- Pneumonia,
- Congestive Heart Failure,
- Cardiac Valve Injury,
- Persistent Pneumothorax (requiring intervention),
- Excessive Pain and Discomfort,
- Deep Sternal Wound Infection,
- Ventricular Arrhythmia (V. Tachycardia or V. Fibrillation)
- New Sinus Node Dysfunction, and
- Drug Reaction

#### ⚠ WARNINGS

- Do not touch the electrodes of the ISOLATOR while activating the ASU. Touching the ISOLATOR electrodes during ASU activation could result in an electrical shock or burn to the operator.
- Do not touch the electrodes of the ISOLATOR to metal staples or clips, or to sutures while activating the ASU. This may damage the ISOLATOR or tissue or result in an incomplete ablation.
- Do not use abrasive cleaners or electrosurgical tip cleaners to clean debris from the Jaws. Use of abrasive cleaners or electrosurgical tip cleaners can damage the electrodes and result in device failure. Use saline-soaked gauze to clean debris off the electrodes.
- Do not immerse any part of the ISOLATOR in liquids as this may damage the device.
- Always wear the appropriate surgical gloves when using the AtriCure ISOLATOR Synergy Surgical Ablation System to avoid shock/burn hazards.
- Inspect the product packaging prior to opening to ensure that the sterility barrier is not breached. If the sterility barrier is breached, do not use the ISOLATOR to avoid the risk of patient infection.
- Electrosurgery should be used with caution in the presence of internal or external pacemakers. Interference produced with the use of electrosurgical devices can cause devices such as a pacemaker to enter an asynchronous mode or can block the pacemaker entirely. Consult the pacemaker manufacturer or hospital Cardiology department for further information when use of electrosurgical appliances is planned in patients with cardiac pacemakers.

#### ⚠ PRECAUTIONS

- Read all instructions carefully for the AtriCure ISOLATOR Synergy Surgical Ablation System, prior to using the device. Failure to properly follow instructions may lead to electrical or thermal injury and may result in improper functioning of the device.
- Use of the ISOLATOR should be limited to properly trained and qualified medical personnel.
- Use ISOLATOR only for cardiac tissue ablation. Variations in specific procedures may occur due to individual physician techniques and patient anatomy.
- Do not drop or toss the ISOLATOR as this may damage the device. If the ISOLATOR is dropped, do not use. Replace with a new ISOLATOR.
- Do not use the ISOLATOR in the presence of flammable materials.
- Do not re-sterilize or reuse the ISOLATOR.
- Keep the Jaws of the ISOLATOR clean of debris during surgery to avoid loss of power.
- Do not use of the ISOLATOR with another manufacturer's generator to avoid damage to the device, which may result in patient injury. The ISOLATOR is only compatible with the AtriCure ASU and ASB3.
- Do not ablate tissue greater than 10 mm thick with the ISOLATOR. Tissues greater than 10 mm thick may not be fully ablated.
- Do not use the ISOLATOR for coagulation or ablation of veins or arteries.
- Inspect the area between the Jaws of the ISOLATOR for foreign matter before activating the ASU or ASB3. Foreign matter captured between the Jaws will adversely affect the ablation.
- Do not insert excessive tissue into the Jaw heel as it may result in poor ablation at the Jaw Heel.
- Do not ablate in pool of blood or other fluids as this may extend the ablation time. Users should suction excess fluids away from the jaws prior to ablation.
- Do not attempt to use an ISOLATOR that has reached its time limit expiration. The ISOLATOR has an 8 hour useful life that is tracked by the ASU. The ISOLATOR will no longer function after 8 hours of use and the ASU will display a message indicating that the ISOLATOR must be replaced.
- Do not use the ISOLATOR if signs of damaged wire insulation are noted upon inspection of the area around the Jaw heel as it may adversely affect ablation performance.
- When the ASU (RF generator) and Handpiece are used on a patient simultaneously with physiological monitoring equipment, ensure that the monitoring electrodes are placed as far as possible from the surgical electrodes. Be sure to position the Handpiece cables so that they do not come in contact with the patient or the other leads.
- Needle monitoring electrodes are not recommended for use when operating the ASU (RF generator) and Handpiece.
- Monitoring systems that incorporate high frequency current limiting devices are recommended for use with the ASU (RF generator) and Handpiece.
- When placing the device, caution should be taken to pull the device into position with a Guide when possible.
- Remove TEE probe during ablation
- When the device is placed around structures per standard surgical technique, caution should be taken to avoid extended circulatory interruption when not on cardiopulmonary bypass.
- When the ASU (RF generator) is activated in conjunction with the Handpiece, the conducted and radiated electrical fields may interfere with other electrical medical equipment. Refer to the ASU IFU for more information regarding potential electromagnetic or other interference, and advice regarding avoidance of such interference.

#### INSTRUCTIONS FOR USE

##### SET UP

1. Examine the packaging of the devices to ensure the sterility of the product has not been breached. Remove the sterilized instruments from their package per standard sterile technique.
2. With the Connector Alignment Arrow symbol in the 12 o'clock position, push the Connector into the appropriate ISOLATOR receptacle on the front of the ASU or ASB3. Each ISOLATOR has a unique receptacle on the ASB3. To ensure device performance, verify proper connections to the ASB3 by consulting the ASB3 package insert. Verify that the connections between the ISOLATOR and the ASU or ASB3 are secure. If the connections are loose, do not use the ISOLATOR. Inspect the Cable and do not use the ISOLATOR if the cable is frayed or the insulation is damaged.

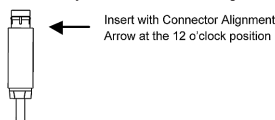

Figure 3

3. If the ISOLATOR is to be used with a supplied GLIDEPATH Tape Instrument Guide (Integrated Guide – Figure 2), go to step 4. If the ISOLATOR is not to be used with the instrument guide, go to step 15.

or re-use of this product, including any loss, damage, or expense which is related to personal injury or damage to property.

#### POSITIONING OF GLIDEPATH TAPE GUIDE

- The Guide may be used with commercially available general dissection or surgical clamping tools (auxiliary tools) to create and maintain a dissection plane that facilitates placement of the ISOLATOR clamp around structures per standard surgical technique.
- Examine the Guide package to ensure the sterility of the product has not been breached. Remove the Guide from its packaging per standard sterile technique.
- Secure the proximal end of the Guide to the sterile drape near the surgical site.
- Insert the distal end of the auxiliary tool completely into the distal pocket of the clear ribbon portion of the Guide.



Figure 4

- Maintain attachment of the distal portion of the Guide to the auxiliary tool during positioning of the Guide.

**Note:** Lubrication may be applied to the Guide at the user's discretion.

- Once the desired placement of the Guide is achieved, use a grasping device to grasp one of the Lateral Tabs (Figure 2) on the Guide and remove the Guide from the auxiliary tool. Externally secure the distal end of the Guide near the surgical site.

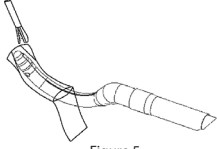

Figure 5

**Note:** If an articulating dissection tool is used, un-articulating the device may facilitate removal of the Guide.

- If desired, the Guide can be used for soft tissue retraction or to introduce additional Instruments through the previously created positioning plane.

#### CONNECTING THE GLIDEPATH TAPE GUIDE

- Inspect the EMR2/EML2 prior to routing. Do Not Use if any defects are present.
- Connect the Guide to the EMR2/EML2 by inserting the Snap Instrument Attachment Tip into the Attachment Tip on the Distal Jaw of the EMR2/EML2.
- Grab the Red Elastic portion of the Guide that is routed around the desired tissue structures.

**Note:** If cardiopulmonary bypass is to be initiated, it is recommended to do so before positioning the ISOLATOR.

- Pull the Guide to position the EMR2/EML2 around desired tissue structures. Keep Jaw Heel away from cannulas, catheters, sutures, and non-target tissue structures.

#### ABLATION

**NOTE:** A minimum tissue incision of 12 mm is recommended for insertion of the ISOLATOR.

- Place the targeted tissue between the Distal and Proximal Jaws.
- Squeeze the Closure Lever to close the Jaws. Ensure that no target tissue extends beyond the Indicator Line on either the Distal or Proximal Jaws or into the Jaw Heel.
- Activate the ASU by depressing the footswitch. When the ASU is activated, the ASU will emit an audible tone indicating that current is flowing between the Jaws of the ISOLATOR. When the continuous tone switches to intermittent, release the footswitch.
- The AtriCure ISOLATOR Synergy Surgical Ablation System measures tissue impedance throughout the ablation cycle and uses this information to control the application of energy to the tissue. The amount of energy delivered to the tissue is driven solely by tissue impedance. The System determines the minimum energy delivery required to create a transmural (full thickness) lesion based on tissue impedance and delivers only that amount of energy to the tissue. Energy delivery changes throughout the ablation cycle as tissue impedance changes. The lesion is visible as a white coloration of the tissue. The device is designed such that the lesions will not spread beyond the jaw width.

Note: The time necessary to create a transmural lesion depends on tissue thickness, composition, and the length of tissue captured between the electrodes.

\*Energy Delivery per unit volume of tissue ablated is comparable between the Isolator Product Lines and below the average of 0.94 J/mm<sup>3</sup> for 2 mm tissue thickness reported for other similar commercially available ablation devices.

- To open the Jaws, press the Release Mechanism and slowly release the Closure Lever. Do not allow the Jaws to spring back. Be aware of any surrounding tissues that could be damaged as the Jaws open.
- Inspect the surgical area to ensure adequate ablation.
- Between ablations, wipe the Jaws clean with a saline-soaked gauze pad. Important: For optimal performance, keep the ISOLATOR electrodes clear of coagulum. To ensure the electrodes are clear of coagulum: Use a saline soaked gauze to clean the electrodes after each ablation. If coagulum is present, it is much easier to remove within the first several seconds after ablation. In a brief period of time, the coagulum could dry out making removal more difficult. Check both electrodes before each ablation to ensure that the gold of the electrode is visible, and coagulum is removed. If the ISOLATOR is idle between ablations, clamp the jaws onto saline soaked gauze to prevent any coagulum on the electrodes from drying.
- Repeat the ablation process as necessary.

#### REMOVAL AND DISPOSAL

- Ensure Guide is removed from the surgical field prior to the completion of the surgical procedure. Discard the Guide after use. Follow local governing ordinances and recycling plans regarding disposal or recycling of device components.
- Discard the ISOLATOR after use. Follow local governing ordinances and recycling plans regarding disposal or recycling of device components.

#### HOW SUPPLIED

The ISOLATOR and Instrument Guide are supplied as STERILE instruments and are for single patient use only.

Sterility is guaranteed unless the package is opened or damaged. Do not resterilize.

#### RETURN OF USED PRODUCT

If for any reason these products must be returned to AtriCure, a return goods authorization (RGA) number is required from AtriCure prior to shipping.

If the products have been in contact with blood or body fluids, they must be thoroughly cleaned and disinfected before packing. They should be shipped in either the original carton or an equivalent carton, to prevent damage during shipment; and they should be properly labeled with an RGA number and an indication of the biohazardous nature of the contents of shipment.

Instructions for cleaning and materials, including appropriate shipping containers, proper labeling, and an RGA number may be obtained from AtriCure, Inc.

**CAUTION:** It is the responsibility of the health care institution to adequately prepare and identify the products for shipment.

#### DISCLAIMER STATEMENTS

Users assume responsibility for approving the acceptable condition of this product before it is used, and for ensuring that the product is only used in the manner described in these instructions for use, including, but not limited to, ensuring that the product is not re-used.

Under no circumstances will AtriCure, Inc. be responsible for any incidental, special or consequential loss, damage, or expense, which is the result of the deliberate misuse

	Non-Pyrogenic
	Sterilized by Ethylene Oxide
	Do Not Re-Use
	Use-by Date
	Lot Number
<b>Rx ONLY</b>	Caution: Federal Law (US) restricts this device to sale by or on the order of a physician
	Caution
	Follow instructions for use
	Does Not Contain Natural Rubber Latex
	Do Not Re-Sterilize
	Do Not Use if Package is Damaged
	Manufacturer
	Catalog Number

**Manufactured by:**  
AtriCure Incorporated  
7555 Innovation Way  
Mason, Ohio 45040 USA

**Customer Service:**  
1-866-349-2342 (toll free)  
1-513-755-4100 (phone)