Isolator™ Transpolar™ pen Instructions for Use (Page 2)



Read
Instructions
Before Use



Latex
Free



Single Use
Only

Rx ONLY

STERILE **EO**

~~PYROGEN~~

For use with the following
Isolator™ Transpolar™ pen models:

MAX1 - A000163

MAX5 -A000625



Isolator™ Transpolar™ pen Instructions for Use

DESCRIPTION

The Isolator™ Transpolar™ pen System is comprised of the AtriCure® Ablation and Sensing Unit (ASU), Isolator™ Transpolar™ pen (Pen) or Isolator™ Long Pen TT (Pen), Footswitch, ASU Source Switch. The Pen is a single patient use electrosurgical instrument designed for use only with the ASU and ASU Source Switch (ASB). The Pen is used to ablate cardiac tissues and as a surgical pacing and mapping tool. When the Pen is connected to the ASU, the ASU provides the bipolar radiofrequency (RF) energy flowing between both electrodes of the Pen. The Operator controls the application of this RF energy by pressing the Footswitch. When the Pen is connected to an auxiliary pace, sense, or stimulation device; the Pen is designed to provide temporary pacing or monitoring. The ASB is a passive device accessory that allows switching between the ASU and an external pacing/monitoring device, such as the Oscor PACE 203 H temporary pacemaker.

ISOLATOR™ TRANSPOLAR™ PEN ILLUSTRATION AND NOMENCLATURE

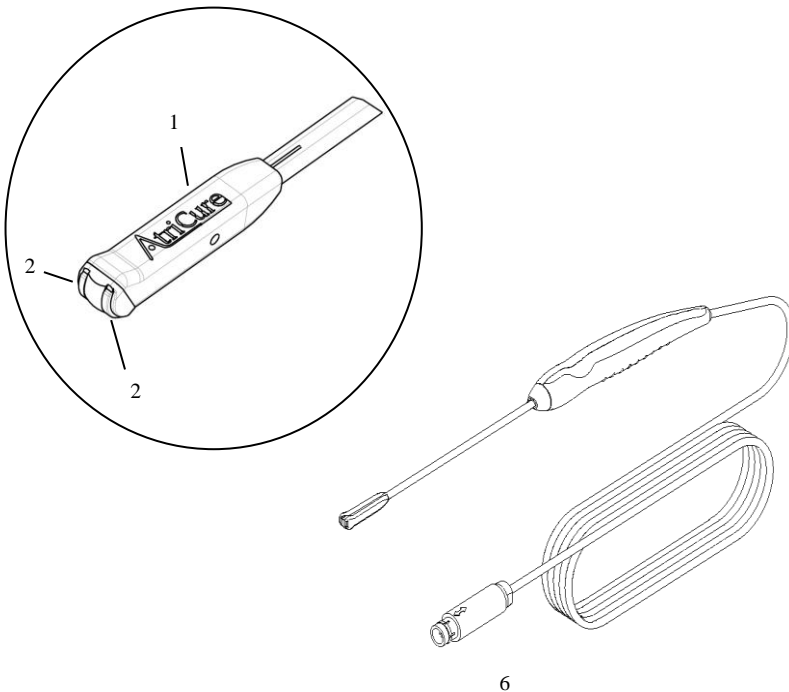

- | | |
|--------------------|--------------------|
| 1. Distal Tip | 5. Cable |
| 2. Electrodes | 6. Connector |
| 3. Malleable Shaft | 7. Alignment Arrow |
| 4. Handle | |

ISOLATOR™ LONG PEN TT ILLUSTRATION AND NOMENCLATURE

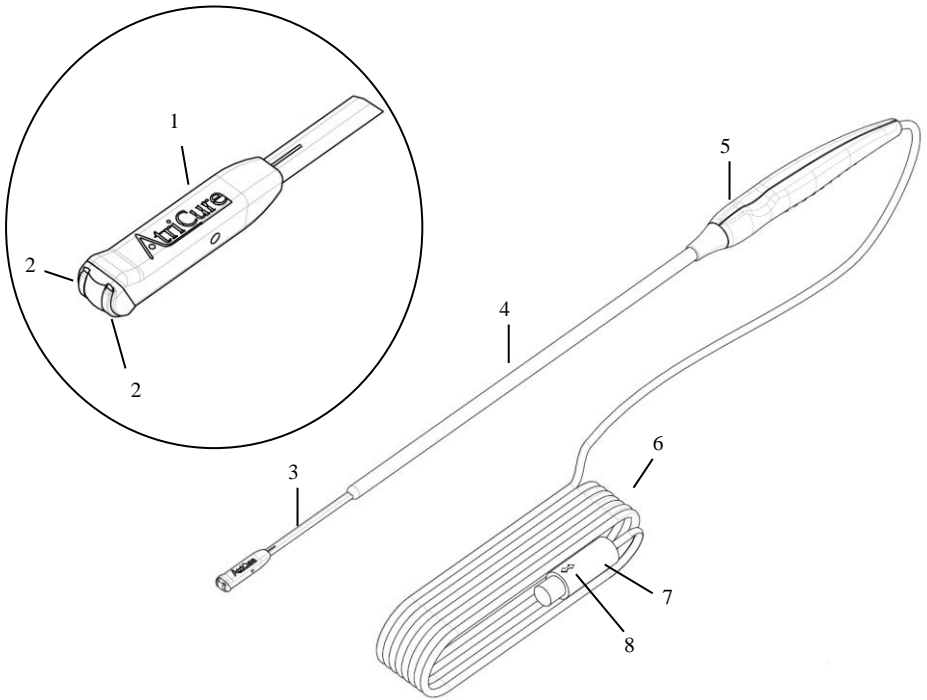

- | | |
|--------------------|--------------------|
| 1. Distal Tip | 5. Handle |
| 2. Electrodes | 6. Cable |
| 3. Malleable Shaft | 7. Connector |
| 4. Rigid Shaft | 8. Alignment Arrow |

INDICATION FOR USE

- The Isolator™ Transpolar™ Pen is a sterile, single use electrosurgery device intended to ablate cardiac tissue during cardiac surgery using radiofrequency (RF) energy when connected directly to the ASU or to the ASU Source Switch in Ablation mode.
- When the Pen is connected to the ASU Source Switch in Auxiliary mode, it may be used for temporary cardiac sensing, recording, stimulation, and temporary pacing during the evaluation of cardiac arrhythmias.

CONTRAINDICATIONS

- The device is not intended for contraceptive tubal coagulation (permanent female sterilization).
- Do not ablate directly on cardiac valves.

POTENTIAL COMPLICATIONS

Possible complications related to the creation of spot or linear lesions in cardiac and soft tissues are:

- Tissue perforation
- Postoperative embolic complications
- Extension of extracorporeal bypass
- Perioperative heart rhythm disturbance (atrial and/or ventricular)
- Pericardial effusion or tamponade
- Injury to the great vessels
- Valve leaflet damage
- Conduction disturbances (SA/AV node)
- Acute ischemic myocardial event



WARNINGS

- Do not touch the electrodes of the Pen while activating the ASU. Touching the Pen electrodes during ASU activation could result in an electrical shock or burn to the operator.
- Do not touch the electrodes of the Pen to metal staples or clips, or to sutures while activating the ASU. This may damage the Pen or tissue, or result in an incomplete ablation.
- Do not use abrasive cleaners or electrosurgical tip cleaners to clean debris from the Distal Tip. Do not turn on ASU while cleaning the device. Use of abrasive cleaners or electrosurgical tip cleaners can damage the electrodes and result in device failure. Use saline-soaked gauze for cleaning debris.
- Do not immerse the Pen in liquids as this may damage the device.
- To avoid shock/burn hazards, always wear the appropriate surgical gloves when using the Pen and ASU.
- To avoid shock/burn hazards, always remove the Pen from the patient during defibrillation.
- No representation or warranty is made that failure or cessation of function of the device will not result in an adverse event or that medical complication (including tissue perforation) will not follow the procedure, or that the use of the device will in all cases restore adequate cardiac function.
- To avoid the risk of patient infection, inspect the product packaging prior to opening to ensure that the sterility barrier is **not** breached. If the sterility barrier is breached, do not use the Pen.
- The pen device is intended for single use only. Do not RESTERILIZE. Resterilization may cause loss of function or injury to patient.
- Use only connecting cables and auxiliary device identified in this Instruction for Use to avoid risk of patient injury, operator injury, or equipment damage.
- Do not allow the connectors of the Pen to get wet. Wet connectors may affect the device performance.
- Read auxiliary device manual and observe warnings. The Pen can be used with a temporary pacemaker.
- Do not connect the ASB auxiliary device cable to supply mains (line voltage) operated equipment without verifying isolation of the connected equipment to EN60601-1-1. Supply mains operated equipment may introduce dangerous leakage currents into the heart
- An auxiliary device may have an adverse effect on nearby radio or TV transmissions. There may also be cases when nearby electrical appliances adversely influence the auxiliary device, causing data errors or malfunction.

PRECAUTIONS

- Read all instructions carefully for the AtriCure® ASU, Isolator™ Transpolar™ Pen, ASU Source Switch, and any auxiliary device being used prior to using the devices. Failure to properly follow instructions may lead to electrical or thermal injury and may result in improper functioning of the device.
- Use of the Pen should be limited to properly trained and qualified medical personnel. Proper surgical procedures and techniques are the responsibility of the medical professional. Understanding the proper use of the Oscor PACE 203 H temporary pacemaker equipment is also the responsibility of the medical professional. Each surgeon must evaluate the appropriateness of any procedure based on their own medical training and experience, and the type of surgical procedure.
- Patient and procedure selection is solely a medical responsibility and the outcome is dependent on many variables including patient pathology, and surgical and perfusion procedures.
- Variations in specific procedures may occur due to individual physician techniques and patient anatomy.
- To avoid damage to the device, do not drop or toss the Pen. If the Pen is dropped, do not use. Replace with a new Pen.
- Do not use the Pen in the presence of flammable materials.
- Do not re-sterilize or reuse the Pen.
- The distal tip of the Pen must be kept clean of debris during surgery to avoid loss of power. Before activating the ASU, inspect the area at the distal tip of the Pen for foreign matter. Foreign matter captured on the tip will adversely affect the ablation.
- The Pen is only compatible with the AtriCure® ASU and ASB. Use of the Pen with another manufacturer's generator may damage the device and result in patient injury.
- The ASB should only be used with FDA approved cardiac pacing and sensing devices.
- Do not use the Pen for coagulation or ablation of veins or arteries.
- Use caution to avoid trauma to tissues not within the target area of ablation. Tissue and/or structures behind the targeted tissue should be protected from potential thermal spread.
- The Pen has an eight hour useful life that is tracked by the ASU. If you attempt to plug in a device that has reached its time limit expiration, the Pen will no longer function and the ASU will display a message indicating that the Pen must be replaced.
- It is the responsibility of the user to dispose of this device in accordance with local regulations.
- Excessive bending of the malleable stainless steel shaft will cause the shaft to harden and may increase the potential for breakage.

INSTRUCTIONS FOR USE Cardiac Ablation Mode

- Using sterile technique, remove the Pen from its packaging. With the Connector Alignment Arrow symbol in the 12 o'clock position, push the Connector into the Pen receptacle on the front of the ASU or ASB. Verify that the connections between the Pen and the ASU are secure. If the connections are loose, do not use the Pen. Inspect the Cable and do not use the Pen if the cable is frayed or the insulation is damaged.

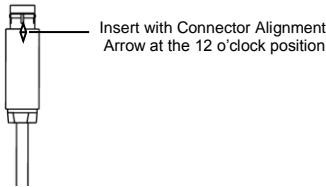

- Under direct visualization, place the distal tip against the targeted cardiac tissue. Assure both electrodes are in contact with targeted tissue.
- Painting ablation technique:**
 - Maintaining visualization, move the distal tip gently across the targeted cardiac tissue.
 - While maintaining continuous contact between the tissue and the electrodes, move the device continuously in an oscillating manner at a rate of approximately 1 cm/sec.

Painting Lesion Depth*

20 seconds 2 cm oscillation
2.0 – 4.0 mm

*Data was obtained from ablations performed on excised bovine myocardium and represent 95% confidence intervals. Results may vary based on live tissue properties.

4. Stamping ablation technique:

- Apply constant firm pressure to the tissue without movement. Maintain full contact of the electrode surface with the tissue. A stamping lesion is approximately 8 mm x 6 mm.
- If creating longer linear lesions with the Stamp technique, overlap the contiguous ablations by 50% to ensure a continuous and complete lesion.

Stamp Lesion Depth*

10 seconds	15 seconds
3.3 - 3.8 mm	3.8 - 4.4 mm

*Data was obtained from ablations performed on excised bovine myocardium and represent 95% confidence intervals. Results may vary based on live tissue properties.

- Press the Footswitch to activate the ASU.
- When the Footswitch is pressed, the ASU will emit an audible tone indicating that current is flowing between the electrodes located at the distal tip of the Pen and through the tissue.
- Inspect the surgical area to ensure adequate ablation.
- Between ablations, wipe the distal tip clean with a saline-soaked gauze pad. Important: For optimal performance, keep the Pen electrodes clear of coagulum. To ensure the electrodes are clear of coagulum:
 - Use saline-soaked gauze to clean the electrodes after each ablation. The coagulum is much easier to remove within the first several seconds after ablation. In a brief period of time, the coagulum may dry, making removal of coagulum more difficult.
 - Check both electrodes before each ablation to ensure that the

gold of the electrode is visible and coagulum is removed.

- 8.3. If the Pen is idle between ablations, place the Pen distal tip onto saline-soaked gauze to prevent any coagulum not cleaned off the electrodes from drying.
9. Repeat ablation if necessary.
10. Upon completion of the surgical procedure, disconnect the Pen from the ASU/ASB and discard the Pen after use. Follow local governing ordinances and recycling plans regarding disposal or recycling of device component.

INSTRUCTIONS FOR USE

Pacing and Mapping Mode

1. Inspect the package and product to ensure the expiration date has not passed and no damage occurred to the product during shipping and handling.
2. Using sterile technique, remove the Pen from its packaging.
3. With the Connector Alignment Arrow symbol in the 12 o'clock position, push the Connector into the Pen receptacle on the front of the ASB. Verify that the connections between the Pen and the ASB are secure. If the connections are loose, do not use the Pen. Inspect the Cable and do not use the Pen if the cable is frayed or the insulation is damaged.

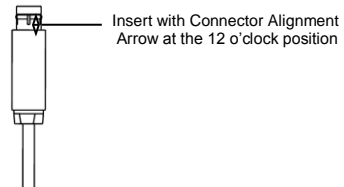

4. A cable with standard 0.080 inch pin tip plugs is provided with the ASB to connect to the auxiliary device. The end of the cable with the single pin tip plug is connected to the ASU Source Switch. The end of the cable with dual pin tip plugs is connected to the auxiliary device.
5. Turn on the temporary pacing or sensing equipment and ensure proper connections to validate electrical continuity. For detailed instructions refer to temporary pacemaker manual.
6. Settings and procedures for the auxiliary device are determined according to the instructions for use provided with the auxiliary device. Set auxiliary device to atrial asynchronous mode (sensing disabled or increased to maximum value).

Note: The Pen will pace when the auxiliary device is in the ON position.

7. Identify and expose the sites for pacing and sensing using standard surgical techniques. Under direct visualization, place the electrodes against the targeted tissue. Assure both electrodes are in contact with targeted tissue.
8. Ensure the pacing is only on when the end effector is in contact with the targeted tissue. The device will pace when the auxiliary device pacing is on.
9. For sensing (mapping), place the distal tip onto the targeted tissue to display the electrogram (EGM).
10. Upon completion of the surgical procedure, disconnect the Pen from the ASB and discard the Pen after use. Follow local governing ordinances and recycling plans regarding disposal or recycling of device component



HOW SUPPLIED

The Isolator™ Transpolar™ pen is supplied as a STERILE instrument and is for single patient use only.

Sterility is guaranteed unless the package is opened or damaged. Do not resterilize.

RETURN OF USED PRODUCT

If for any reason this product must be returned to AtriCure®, Inc., a return goods authorization (RGA) number is required from AtriCure®, Inc., prior to shipping.

If the product has been in contact with blood or body fluids, it must be thoroughly cleaned and disinfected before packing. It should be shipped in either the original carton or an equivalent carton, to prevent damage during shipment; and it should be properly labeled with an RGA number and an indication of the biohazardous nature of the contents of shipment.

Instructions for cleaning and materials, including appropriate shipping containers, proper labeling, and an RGA number may be obtained from AtriCure®, Inc.

CAUTION: It is the responsibility of the health care institution to adequately prepare and identify the product for shipment.

DISCLAIMER STATEMENTS









Users must assume responsibility for approving the condition of this product before it is used. AtriCure®, Inc., cannot be held liable for any consequential damage, personal injury or damage to property nor for the misuse of this product.

AtriCure, Inc., will not be liable for any damage caused by the reuse of this product.

This Instruction for Use describes the procedures for proper use of the product. Any deviation from these procedures, which may compromise the function of the product, is the responsibility of the user.

Explanation of symbols on package labeling

Refer to the outer package label to see which symbols apply to this product.

 Non-Pyrogenic
 Sterilized by Ethylene Oxide
 Single Use Only
 Expiration Date
 Lot Number
Rx ONLY Caution: Federal Law (USA) restricts this device to sale by or on the order of a physician
 Attention. See Instructions for Use
 Latex Free
 Follow Instructions for Use

CE
0086
CE Mark with Notified Body - class II and III medical devices comply with EC Directive 93/42/EEC

Manufactured by:
AtriCure Incorporated
7555 Innovation Way
Mason, Ohio 45040 USA
Customer Service:
1-866-349-2342 (toll free)
1-513-755-4100 (phone)
