

Carefully Read All Instructions Prior to Use.

PACKAGING AND STORAGE

The LARIAT RS Suture Delivery Device is sterile (using ethylene oxide gas) and non-pyrogenic in unopened packaging that is designed to maintain sterility unless the primary product pouch has been opened or damaged.

Handle with care. Do not store in excessive heat. After use, this product may be a potential biohazard. Handle and dispose of all such devices in accordance with accepted medical practice and applicable local, state, and federal laws and regulations.

INDICATIONS

The LARIAT RS Suture Delivery Device facilitates suture placement and knot tying for use in surgical applications where soft tissue are being approximated and/or ligated with a pre-tied polyester suture.

DESCRIPTION

The LARIAT RS Suture Delivery Device (Figure 1) is a one-piece, single-use suture delivery and deployment device with a pre-tied size 0 polyester suture loop that is pre-loaded on the device. A lumen within the LARIAT RS is designed for aspiration, flushing during the delivery, capture, or release of the LARIAT RS Suture. The SofTIP™ Guide Cannula and dilator, which may be used for straightening, guidance and placement of the LARIAT RS, are packaged separately.

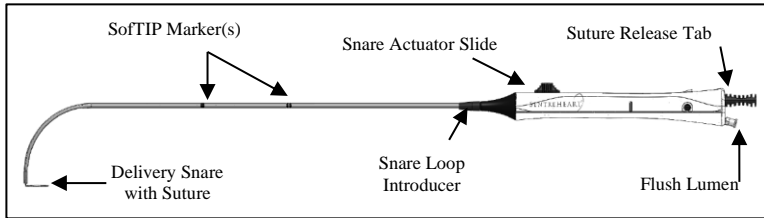

Figure 1 LARIAT RS Suture Delivery Device

The LARIAT RS Suture is a sterile, braided, non-absorbable, surgical suture, dyed D & C Green No. 6 composed of Poly(ethylene terephthalate) that is prepared from fibers of high molecular weight, long-chain, linear polyesters having recurrent aromatic rings as an integral component. The Polyester Suture meets all requirements established by the United States Pharmacopeia (U.S.P.) for Non-absorbable Surgical Sutures.

Users should be familiar with minimally invasive procedures, surgical procedures, and techniques involving non-absorbable sutures before employing the LARIAT RS for approximation or ligation. Consult the medical literature relative to techniques, complications, and hazards.

CONTRAINDICATIONS

- The LARIAT RS is not intended for use where minimally invasive techniques are contraindicated.
- The LARIAT RS is not intended for use as a contraceptive tubal occlusion.
- The LARIAT RS is not intended for use where polyester suture is contraindicated for use.
- Do not use the LARIAT RS on anatomical structures with a diameter exceeding 50 mm and/or a length exceeding 70 mm.
- Do not use this device if pre-existing condition of local or systemic infection and/or endocarditis or pericarditis is present.
- Do not introduce the LARIAT RS through an introducer sheath with a hemostasis valve.

POTENTIAL REACTIONS

Potential reactions associated with the use of a Suture Delivery Device include wound dehiscence, infection, minimal acute inflammatory tissue reaction, and transitory local irritation at the wound site.

! WARNINGS

- As with any foreign body, prolonged contact of any suture with salt solutions, such as those found in the urinary and biliary tracts, may result in calculus formation. Acceptable surgical practice must be followed for the management of infected or contaminated wounds.
- At no time should the LARIAT RS be advanced or withdrawn when resistance is met without first determining the cause.
- The LARIAT RS is intended for single use. Upon deployment of the suture, the device cannot be re-used since the pre-tied suture loop is unable to be re-loaded onto the Delivery Snare.

- For single use only. Do not reuse, reprocess or re-sterilize. Reuse, reprocessing or re-sterilization may compromise the structural integrity of the device and/or lead to device failure, which in turn may result in patient injury, illness or death. Reuse, reprocessing or re-sterilization may also create a risk of contamination of the device and/or cause patient infection or cross-infection, including, but not limited to, the transmission of infectious disease(s) from one patient to another. Contamination of the device may lead to injury, illness or death of the patient.

! PRECAUTIONS

- The safety and effectiveness of this product has not been determined for laparoscopic procedures which are not yet established. Care should be exercised when considering performance characteristics and methods of use in such applications.
- When cutting excess suture after tightening, care should be taken not to cut the pre-tied LARIAT RS knot, which may result in loosening or incomplete closure.

INSTRUCTIONS FOR USE

Preparation

1. Carefully inspect all devices and their packaging prior to use. Do not use a device that is damaged in any way or its packaging is damaged.
2. Open the package and discard the outer package material. The inner tray and contents are sterile and should be handled in a sterile fashion.
3. Remove the LARIAT RS from the packaging, taking precautions to avoid damage to the exposed Delivery Snare located at the distal end.
4. Confirm snare actuation by retracting and opening Snare Actuator Slide.
5. Carefully inspect the exposed Delivery Snare for any damage or deployed Suture.

NOTE: If suture appears exposed or partially released from Delivery Snare it is recommended to use another device.

Placement

6. If using the SofTIP Long Guide Cannula (60-02) (sold separately), position the SofTIP at desired location. Do not use the LARIAT RS in a trocar, cannula or incision size less than 4.3 mm.
7. If using a guidewire, do not use a guidewire with a diameter exceeding 0.035".

! PRECAUTION: Do not actuate (open and close) the Delivery Snare excessively or the pre-tied Suture may prematurely release from the Delivery Snare.

! PRECAUTION: Do not pull the red Suture Release Tab or the pre-tied Suture may prematurely release from the Delivery Snare.

8. Close the LARIAT RS Delivery Snare by sliding the Snare Actuator Slide located on the top of the handle as shown in Figure 2. Retract until the Snare Actuator Slide stops as indicated by the "-" symbol or until resistance is felt.

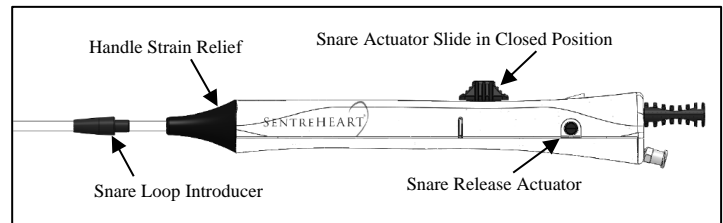

Figure 2 Closing the Delivery Snare

9. If using the SofTIP or Trocar, advance the Snare Loop Introducer from the handle towards the tip until it covers the closed Delivery Snare. Introduce the LARIAT RS into the SofTIP or Trocar. Pull back the Snare Loop Introducer until it locks to the Handle Strain Relief as shown in Figure 3.

With the Delivery Snare remaining in the closed position, advance the LARIAT RS within proximity of the tissue to be approximated or ligated.

NOTE: Ensure that the LARIAT RS is free and clear of the SofTIP tip and any other anatomical structure or instrumentation. If using the SofTIP, the LARIAT RS may be opened after the distal marker located on the LARIAT RS catheter body is no longer visible.

10. To open the Delivery Snare, advance the Snare Actuator Slide until it stops and Delivery Snare is fully open as represented by the "O" (oval) symbol as shown in Figure 3.

! PRECAUTION: Ensure that the distal black marker on the LARIAT RS catheter shaft is not visible prior to opening the Delivery Snare.

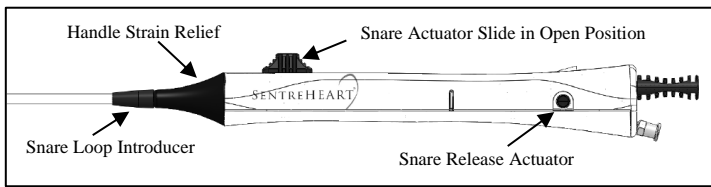

Figure 3 Opening the Delivery Snare

- Using the handle to direct the LARIAT RS, advance the opened Delivery Snare over the tissue to be approximated or ligated.

WARNING: During advancement over tissue do not twist or rotate the device continuously in one direction to avoid twisting of the Delivery Snare and/or Suture. Never rotate the device 360 degrees.

NOTE: Some manipulation including rocking of the device may be necessary while advancing over the targeted tissue.

Closure Instructions

- Ensure the open Delivery Snare is at the desired target for ligation. The Delivery Snare represents the position where the Suture will be placed. Orientate the LARIAT RS curve to the target tissue as shown in Figure 4A.
- If using fluoroscopic guidance to advance the LARIAT RS over the target tissue, a marker on the distal tip provides a fluoroscopic reference for the tip position of the open snare. See Figure 4B

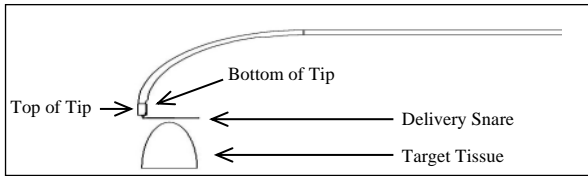

Figure 4A LARIAT + Orientation

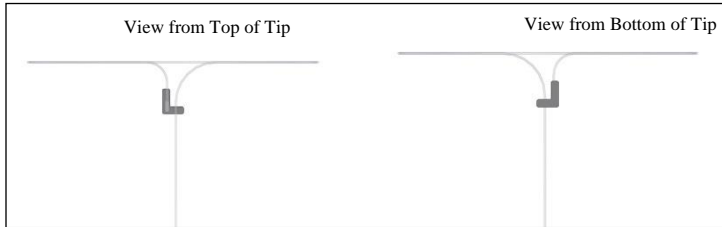

Figure 4B Fluoroscopic View of Orientation Marker on Tip

NOTE: Prior to closing the Delivery Snare ensure non-targeted tissue and instrumentation are free of the closure site.

PRECAUTION: If resistance during closure is felt prior to the stop, do not attempt to close any further. Continue to step 15. Do not pull the Snare Actuator Slide beyond the stop point of the device as indicated by the "-" symbol.

- Retract the Snare Actuator Slide to the closed position ("-" symbol) or where tactile resistance is felt.
- Locate the red Suture Release Tab at the back end of the LARIAT RS as shown in Figure 1.
- Grasp the red Suture Release Tab while holding the LARIAT RS handle stable.

PRECAUTION: Avoid sudden or extreme force during suture deployment as suture may pre-maturely break.

PRECAUTION: Failure to hold the LARIAT RS stable could result in failure to deploy the suture. Failure to completely deploy the Suture from the LARIAT RS may result in failure to ligate.

- Gently and smoothly pull back the red Suture Release Tab completely until the desired tissue approximation is achieved using standard knot pushing technique.
- Additional tightening of the suture may be required for complete ligation or approximation.

NOTE: While pulling excess suture during tightening with the red Suture Release Tab the suture will be black. When the suture turns to green this indicates initiation of the tightening around tissue.

Removal Instructions

WARNING: If resistance is felt during opening of the LARIAT RS snare, **DO NOT** attempt to force the Actuator Slide. Stop to identify potential causes. Clear any constraints that may be interfering with opening. Release the LARIAT RS to eliminate any forward force. Gently retract the LARIAT RS while opening Actuator Slide.

- To remove the LARIAT RS, fully open the Delivery Snare as indicated by the "O" (oval) symbol.
- Cut the excess Suture at the Suture Release Tab to allow for the LARIAT RS to be removed. See Figure 5.

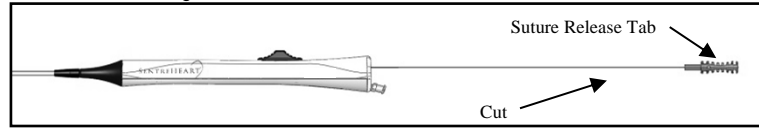

Figure 5 Suture Cutting

WARNING: Do not rotate or twist the LARIAT RS during removal from the ligated tissue.

PRECAUTION: If resistance is felt during removal of the LARIAT RS device, **DO NOT** attempt to force removal and stop to identify potential causes. Verify the Suture Release Tab is removed, Delivery Snare is open, Suture is fully deployed and device is free of anatomical constraints or instrument interference.

- If device cannot be freed from anatomical constraints, grasp the Suture Release Tab and fully insert it into the Snare Release Actuator opening on the side of the handle, as shown in Figure 6, to release the snare loop. Continue to hold the tip against tissue, remove the restrictor plate as shown in Figure 7. Finally, retract the snare actuator slide completely proximal as shown in Figure 8.

NOTE: Prior to release of snare loop, apply light tension to suture to minimize possibility of entanglement with snare.

NOTE: Ensure the restrictor plate has been fully removed (refer to Figure 7). If necessary, re-insert suture release tab into the snare release actuator.

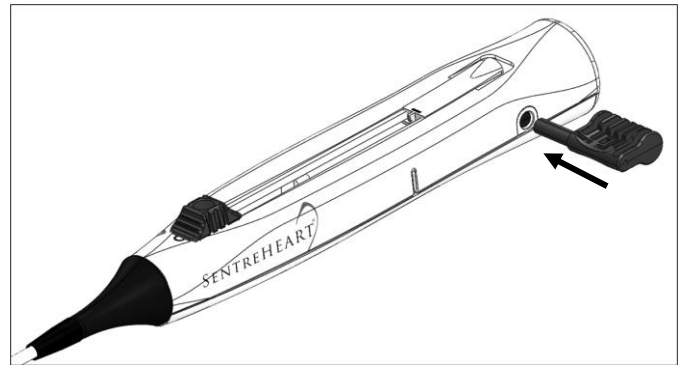

Figure 6 Suture Release Tab inserted into Snare Release Actuator

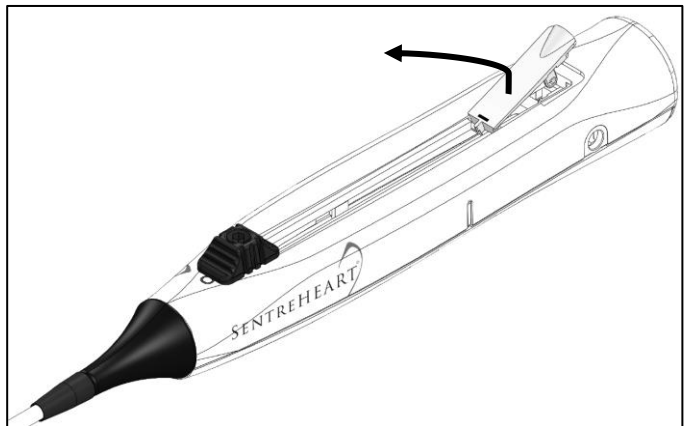

Figure 7 Lift and Remove Restrictor Plate

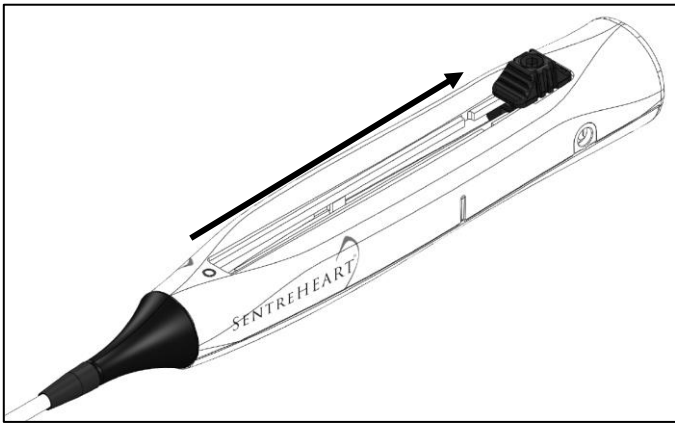

Figure 8 Completely Retract Snare Actuator Slide

22. Grasping the handle, gently withdraw the LARIAT RS until the Delivery Snare is no longer on the ligated tissue.

PRECAUTION: If removing the LARIAT RS without having deployed the suture it is recommended to close the Delivery Snare to the “-“ symbol when withdrawing from SofTIP.

PRECAUTION: If using a guidewire, when removing the LARIAT RS through the SofTIP it is necessary to either completely remove the guidewire or ensure the wire is through and distal to the snare. A guidewire outside of the snare may cause excess resistance or prevent the device from being removed through the SofTIP.

23. Remove the LARIAT RS from the operative field. If using the SofTIP it is not necessary to close the Delivery Snare when withdrawing through the SofTIP.

PRECAUTION: Cutting of the LARIAT RS knot may result in incomplete ligation or approximation of the tissue.

24. Cut the excess Suture at the desired length taking precautions not to cut the knot of the LARIAT RS.

Catalog Number:	REF
Batch Code:	LOT
Use By:	
Contents of the package:	CONTENTS
Non-pyrogenic	
Do Not Reuse:	
Do Not Re-sterilize:	
Do not use if packaging is damaged:	
Keep Away From Sunlight:	
Keep Dry:	
Caution	
Consult Instructions For Use:	
CAUTION: Federal law (US) restricts this device to sale by or on the order of a physician:	R_{only}
Sterilized using ethylene oxide:	STERILE EO
<p>Manufactured By:</p> <p>AtriCure Inc 7555 Innovation Way Mason, Ohio 45040 1.866.349.2342 www.atricure.com</p>	

